



川源(中国)机械有限公司  
GSD (China) Co.,Ltd.



# GPS

## 卧式直接式离心泵

GPS coaxial pump

# GPS卧式直接式离心泵

## GPS Coaxial Pump



### 用途Application

- 暖通空调冷热水循环系统 Air-condition cold or hot water circulation
- 设备配套 Can be used together with equipment
- 高楼给水 Water-supplying system of apartment building
- 一般工业用水 Industrial water supply
- 消防给水 Fire-fighting water system
- 土木施工用水 Construction engineering water supply
- 污水处理设备 Waste water treatment
- 农业灌溉用水 Farm water irrigation
- 锅炉给水 Boiler water supply



## 特点

- 叶轮采用优秀的水力模型设计，具有极好的动静平衡，性能稳定。
- 以电机轴作为泵轴，同心度绝对可靠。
- 采用进口轴承，振动小，噪音低。
- 单吸、单级卧式离心泵，闭式叶轮。
- 同轴直接式构造，效率高，体积小，重量轻，安装保养容易。
- 采用机械密封，不损轴心，不漏水，使用寿命长。
- 可根据要求采用不同材质。（本型录为铸铁材质，若选用不锈钢材质，则尺寸及重量另行提供。）

## Features

- The optimal hydraulic model is used for impeller, the pump is of an utmost dynamic-static balance and reliable performance.
- The pump shaft is an extended one from the motor, so the concentricity is absolutely reliable.
- The pump which is supported by imported bearing, runs at little vibration and low noise.
- Single-stage single-suction horizontal centrifugal pump, closed impeller .
- Coaxial volute structure, high efficiency, small volume, light weight, easy installation and maintenance.
- Mechanical seal, no damage to shaft, no leakage, long duration.
- Materials can be selected according to the requirement of the customer. (Material of the pump model in the catalog is cast iron. The size and weight of the pump made of stainless steel can be provided separately.)

## 结构简图 Construction

NO.	名称	Name	材质	
			GB	Material
1	主轴	Shaft	1Cr13	SUS410
2	中承座	Bracket	HT200	FC200
3	泵体	Pump casing	HT200	FC200
4	螺栓	Plug	Q215A	SS34(SS330)
5	O型圈	O-ring	NBR	NBR
6	机械密封	Mechanical seal	C/AL <sub>2</sub> O <sub>3</sub>	C/AL <sub>2</sub> O <sub>3</sub>
7	叶轮	Impeller	HT200	FC200
8	键	Key	45	S45C
9	机座	Feet	HT200/Q215A	FC200/SS34(SS330)
10	电机	Motor		

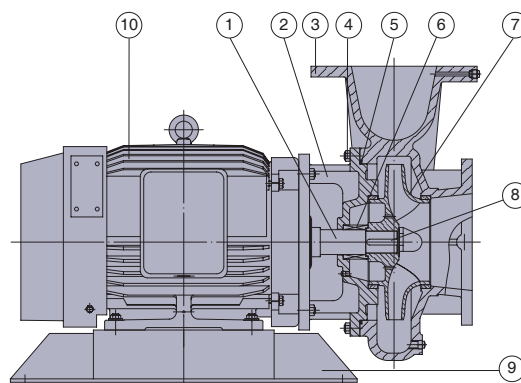

## 型号说明 Type description

G - 3 10 - 100

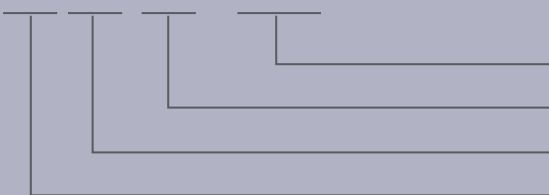

进口口径      Suc. diameter (mm)  
 额定功率      Rated power (hp)  
 相 数          Phase  
 直接式泵浦    Coaxial pump



## 型谱图 Performance chart

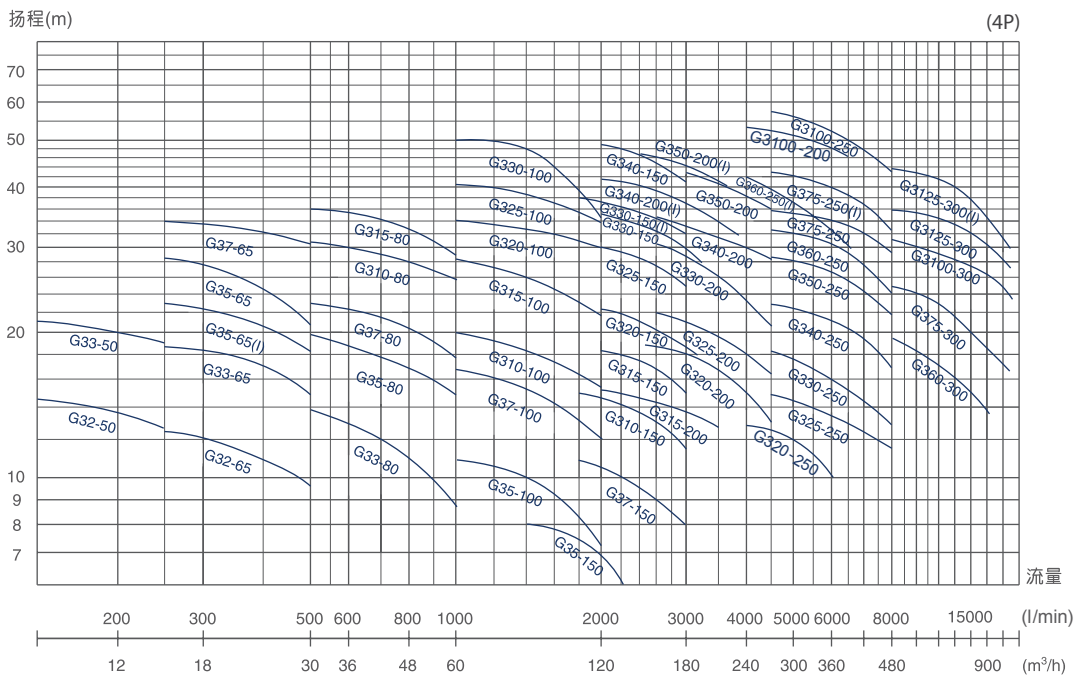
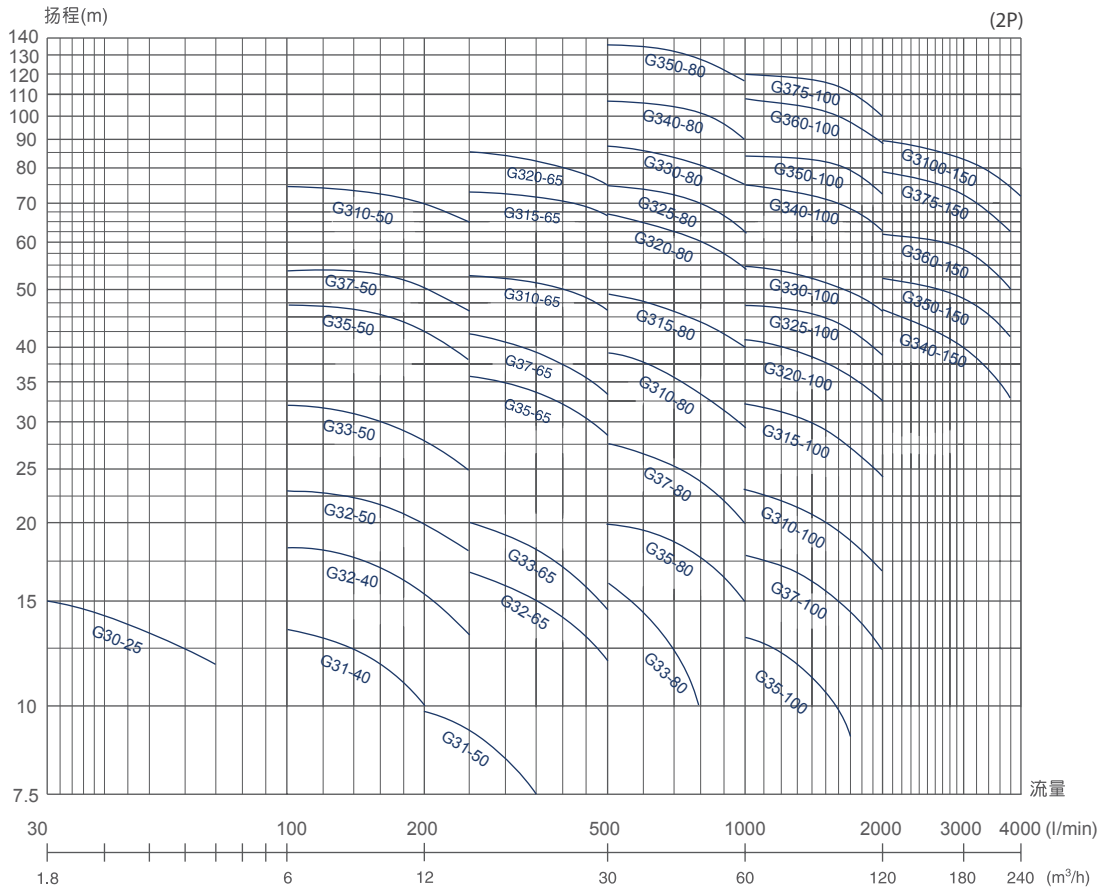

## 性能参数 Performance parameters

(2P)

型号 Type	转速 Speed (r/min)	流量 Capacity (m <sup>3</sup> /h)	扬程 Head(m)	效率 Eff(%)	电动机功率 Motor power		必须气蚀余量 Npshr(m)	口径 Dia.(mm)	重量 Weight(kg)
					(hp)	(kW)			
G-30-25	2900	2.0	15	30	0.5	0.37	2.0	25	24
		2.5	13	35			2.0		
		3.0	12	34			2.0		
G-31-40	2900	7.2	13	50	1	0.75	2.0	40	30
		9	11.5	55			2.0		
		10.8	10.5	54			2.0		
G-32-40	2900	8.8	17.5	52	2	1.5	2.0	40	35
		11	16	58			2.0		
		13.2	14	57			2.2		
G-31-50	2900	12.8	9.5	51	1	0.75	2.0	50	28
		16	8	55			2.0		
		19.2	7	54			2.2		
G-32-50	2900	8.8	21.5	58	2	1.5	2.0	50	39
		12.5	20	66			2.0		
		16.3	17.8	65			2.2		
G-33-50	2900	9.4	29.5	47	3	2.2	2.0	50	52
		11.7	28	52			2.0		
		14	25	50			2.4		
G-35-50	2900	9.4	46	43	5	3.7	2.0	50	72
		11.7	44	46			2.0		
		13	40	45			2.5		
G-37-50	2900	10	52	46	7.5	5.5	2.1	50	80
		12.5	50	48			2.2		
		15	47	46			2.5		
G-310-50	2900	9.4	72	31	10	7.5	2.2	50	108
		11.7	70	36			2.4		
		13	66	34			2.5		
G-32-65	2900	16.8	16.5	60	2	1.5	2.0	65	41
		21	15	67			2.0		
		25.2	13	66			2.5		
G-33-65	2900	16	20	61	3	2.2	2.2	65	43
		22.3	18	63			2.2		
		29	14	58			2.5		
G-35-65	2900	20	34	60	5	3.7	2.0	65	76
		25	32	65			2.0		
		30	28	64			2.5		
G-37-65	2900	17.4	40.5	50	7.5	5.5	2.0	65	92
		21.7	38	56			2.0		
		26	34	54			2.5		
G-310-65	2900	20	51.5	57	10	7.5	2.0	65	102
		25	50	61			2.0		
		30	47	60			2.5		
G-315-65	2900	18.4	72	48	15	11	2.0	65	145
		23	70	62			2.0		
		27.6	66.5	51			2.5		
G-320-65	2900	20	82	37	20	15	2.0	65	174
		25	80	50			2.0		
		30	74	53			2.5		
G-33-80	2900	32	16	64	3	22	3.0	80	65
		40	12	65			3.0		
		46	10	58			3.5		
G-35-80	2900	35.8	18	66	5	3.7	3.0	80	71
		44.7	16	73			3.0		
		53.6	14	72			3.5		
G-37-80	2900	34.6	26	66	7.5	5.5	2.5	80	98
		43.3	24	69			2.5		
		52	21	67			2.5		
G-310-80	2900	32	38	60	10	7.5	2.5	80	106
		40	36	67			2.5		
		48	33	66			3.0		
G-315-80	2900	37.4	46.5	61	15	11	2.5	80	157
		46.8	44	67			2.5		
		56.2	41	66			3.0		
G-320-80	2900	34.6	64	53	20	15	2.5	80	181
		43.3	60	59			2.5		
		52	57	58			3.0		
G-325-80	2900	37	73.5	50	25	18.5	2.5	80	205
		46.8	70	61			2.5		
		56	65	60			3.0		



## 性能参数 Performance parameters

(2P)

型号 Type	转速 Speed (r/min)	流量 Capacity (m <sup>3</sup> /h)	扬程 Head(m)	效率 Eff(%)	电动机功率 Motor power		必须气蚀余量 Npshr(m)	口径 Dia.(mm)	重量 Weight(kg)
					(hp)	(kW)			
G-330-80	2900	40	84	54	30	22	2.5	80	250
		50	80	63			2.5		
		60	75	62			3.0		
G-340-80	2900	36.4	108	46	40	30	3.0	80	262
		45.4	103	50			3.0		
		54.5	93	49			3.0		
G-350-80	2900	40	132	49	50	37	3.0	80	410
		50	125	54			3.0		
		60	119	53			3.5		
G-35-100	2900	56	13.5	66	5	3.7	3.5	100	77
		70	12	73			4.0		
		84	10	72			4.5		
G-37-100	2900	68	17.5	68	7.5	5.5	4.0	100	96
		85	16	76			4.5		
		102	14	75			4.5		
G-310-100	2900	72	22.5	69	10	7.5	4.0	100	97
		90	20	76			4.5		
		108	18	75			5.0		
G-315-100	2900	72	31.5	71	15	11	3.5	100	168
		90	28	77			4.0		
		108	26	76			5.0		
G-320-100	2900	69.2	40	67	20	15	3.0	100	174
		86.6	38	72			3.5		
		102	34.5	71			3.6		
G-325-100	2900	74.8	46	68	25	18.5	2.5	100	210
		93.5	44	74			2.5		
		112.2	40	73			3.0		
G-330-100	2900	80	52.5	68	30	22	3.0	100	260
		100	50	76			3.5		
		120	46	75			4.0		
G-340-100	2900	74.8	74	65	40	30	2.5	100	281
		93.5	70	70			3.5		
		112.2	64	69			4.0		
G-350-100	2900	80	84	65	50	37	2.5	100	352
		100	80	70			3.5		
		120	72	69			4.0		
G-360-100	2900	72	106	54	60	45	2.5	100	387
		90	100	62			3.5		
		108	91	60			4.0		
G-375-100	2900	76.4	118	58	75	55	3.0	100	448
		95.5	114	64			3.0		
		115	102	63			4.0		
G-340-150	2900	144	43	71	40	30	3.1	150	375
		180	40	76			3.1		
		216	35	75			3.4		
G-350-150	2900	144	51	70	50	37	3.0	150	410
		180	48	75			3.0		
		216	43.5	74			4.0		
G-360-150	2900	144	61	70	60	45	3.5	150	438
		180	58	75			3.5		
		216	52	74			4.5		
G-375-150	2900	150	76	68	75	55	4.0	150	465
		187	70	74			4.0		
		224	73	73			5.0		
G-3100-150	2900	160	85	68	100	75	4.0	150	545
		200	80	78			4.2		
		240	72	76			5.0		



## 性能参数 Performance parameters

(4P)

型号 Type	转速 Speed (r/min)	流量 Capacity (m <sup>3</sup> /h)	扬程 Head(m)	效率 Eff(%)	电动机功率 Motor power		必须气蚀余量 Npshr(m)	口径 Dia.(mm)	重量 Weight(kg)
					(hp)	(kW)			
G-32-50	1450	8.6	16.5	39	2	1.5	2.5	50	63
		10.8	15	44			2.5		
		13.0	14	43			3.0		
G-33-50	1450	7.5	21	35	3	2.2	2.0	50	68
		12.5	20	46			2.0		
		15	19.4	45			2.5		
G-32-65	1450	18.7	11.8	56	2	1.5	2.5	65	53
		23.4	11	63			2.5		
		28	10.2	62			3.0		
G-33-65	1450	18.7	18.3	53	3	2.2	2.5	65	74
		23.4	17	58			2.5		
		28	15.5	52			3.0		
G-35-65(I)	1450	20	22	54	5	3.7	2.5	65	105
		25	20	60			2.5		
		30	18.5	59			3.0		
G-35-65	1450	17	27	42	5	3.7	2.5	65	105
		21.4	25	47			2.5		
		25.6	22.5	45			3.0		
G-37-65	1450	20	33	48	7.5	5.5	2.5	65	130
		25	32	54			2.5		
		30	30.8	53			3.0		
G-33-80	1450	32	14	56	3	2.2	2.0	80	83
		40	12	63			2.0		
		48	9	62			2.5		
G-35-80	1450	37	18.7	59	5	3.7	2.0	80	96
		46.7	17	64			2.0		
		56	16.6	63			2.5		
G-37-80	1450	40	22	60	7.5	5.5	2.0	80	109
		50	20	66			2.0		
		60	18	65			2.5		
G-310-80	1450	37	30	56	10	7.5	2.0	80	144
		46.7	28	62			2.0		
		56	26.5	61			2.5		
G-315-80	1450	40	34.2	60	15	11	2.0	80	188
		50	32	64			2.0		
		60	29	63			2.5		
G-35-100	1450	69.2	10.5	66	5	3.7	2.5	100	100
		86.5	9.5	71			2.5		
		103.8	8	70			3.0		
G-37-100	1450	69.2	16.6	67	7.5	5.5	2.5	100	126
		89.5	15	73			2.5		
		103.8	13.2	72			3.0		
G-310-100	1450	74.8	18.5	69	10	7.5	2.5	100	140
		93.5	17.5	74			2.5		
		112.2	16	73			3.0		
G-315-100	1450	72.6	27.2	62	15	11	2.5	100	198
		90.8	25.8	69			2.5		
		109	22.8	68			3.0		
G-320-100	1450	80	33.5	67	20	15	2.5	100	227
		100	32	72			2.5		
		120	29.5	71			3.0		
G-325-100	1450	72	40	58	25	18.5	2.5	100	320
		90	38	62			2.5		
		108	35.5	61			3.0		
G-330-100	1450	76	47	58	30	22	2.5	100	342
		95	44	64			2.5		
		114	38	63			3.0		
G-35-150	1450	96	8	67	5	3.7	3.0	150	112
		120	7	73			3.0		
		144	5	72			3.5		
G-37-150	1450	108	11	71	7.5	5.5	3.0	150	202
		130	10	75			3.0		
		156	9	74			3.5		
G-310-150	1450	107	15	71	10	7.5	3.0	150	151
		134	14	79			3.0		
		160	12.5	78			3.5		
G-315-150	1450	120	18.5	74	15	11	2.5	150	202
		147	17	81			2.5		
		180	15	80			3.0		



## 性能参数 Performance parameters

(4P)

型号 Type	转速 Speed (r/min)	流量 Capacity (m³/h)	扬程 Head(m)	效率 Eff(%)	电动机率 Motor power		必须气蚀余量 Npshr(m)	口径 Dia.(mm)	重量 Weight(kg)
					(hp)	(kW)			
G-320-150	1450	128	21.5	75	20	15	2.5	150	232
		160	20	82			2.5		
		192	18	81			3.0		
G-325-150	1450	120	30	66	25	18.5	2.5	150	284
		150	28	73			2.5		
		180	25	72			3.0		
G-330-150(I)	1450	108	38	69	30	22	3.0	150	323
		130	36	71			3.0		
		156	33	70			3.5		
G-330-150	1450	128	34.8	68	30	22	2.5	150	310
		160	32	74			2.5		
		192	28	73			3.0		
G-340-150	1450	120	48.5	66	40	30	3.0	150	373
		150	45	72			3.0		
		180	41	71			3.5		
G-315-200	1450	133	15	68	15	11	3.0	200	215
		167	14	76			3.0		
		200	13	75			3.0		
G-320-200	1450	148	19	72	20	15	2.5	200	237
		185	17	78			2.5		
		222	15	77			3.0		
G-325-200	1450	160	21.5	72	25	18.5	2.5	200	308
		200	20	80			2.5		
		240	18	78			3.0		
G-330-200	1450	148	31	72	30	22	3.0	200	324
		185	28	78			3.0		
		222	24	77			3.5		
G-340-200(I)	1450	136	41	66	40	30	2.5	200	360
		170	38	72			2.5		
		204	34	71			3.0		
G-340-200	1450	160	34.6	72	40	30	3.0	200	336
		200	32	79			3.0		
		240	30	78			3.5		
G-350-200(I)	1450	144	46.5	69	50	37	3.0	200	532
		180	44	75			3.5		
		216	40.5	73			4.0		
G-350-200	1450	176	43	70	50	37	3.0	200	462
		200	40	76			3.5		
		264	36	74			4.0		
G-3100-200	1450	240	52	72	100	75	4.5	200	782
		300	50	79			4.5		
		400	47	78			5.0		
G-320-250	1450	240	13	73	20	15	3.0	250	290
		300	12	75			3.5		
		360	10	69			4.0		
G-325-250	1450	264	15	75	25	18.5	4.0	250	334
		330	14	78			5.0		
		396	13	77			6.0		
G-330-250	1450	288	18	73	30	22	4.0	250	351
		360	16	79			5.0		
		432	14	78			6.0		
G-340-250	1450	320	22	74	40	30	3.0	250	416
		400	20	80			3.5		
		480	17	79			5.0		
G-350-250	1450	304	28	72	50	37	3.5	250	476
		380	26	78			4.0		
		456	22	77			5.0		
G-360-250(I)	1450	264	40	73	60	45	5.0	250	536
		330	35	79			5.0		
		396	28	78			5.5		
G-360-250	1450	320	31	72	60	45	3.5	250	536
		400	28	78			4.0		
		480	24	77			5.0		
G-375-250(I)	1450	288	43	75	75	55	5.0	250	578
		360	40	80			5.5		
		432	35	79			5.2		





## 性能参数 Performance parameters

(4P)

型号 Type	转速 Speed (r/min)	流量 Capacity (m <sup>3</sup> /h)	扬程 Head(m)	效率 Eff(%)	电动功率 Motor power		必须气蚀余量 Npshr(m)	口径 Dia.(mm)	重量 Weight(kg)
					(hp)	(kW)			
G-375-250	1450	320	34.5	75	75	55	5.0	250	578
		400	32	81			5.5		
		480	28.5	80			6.0		
G-3100-250	1450	320	56	75	100	75	5.0	250	830
		400	50	81			5.0		
		480	42	80			5.5		
G-360-300	1450	500	19.5	74	60	45	5.5	300	623
		600	17	79			5.5		
		700	15	76.5			5.5		
G-375-300	1450	480	25	76	75	55	6.0	300	770
		600	23	81			6.0		
		720	20	80			6.6		
G-3100-300	1450	528	31	74	100	75	6.0	300	910
		660	28	80			6.0		
		792	25.5	79			6.0		
G-3125-300(I)	1450	528	43	75	125	90	5.0	300	1015
		660	40	81			5.0		
		792	33	80			5.5		
G-3125-300	1450	576	34	75	125	90	5.0	300	1015
		720	32	80			5.0		
		864	27	79			5.5		



## 外形及安装尺寸 Installation dimensions

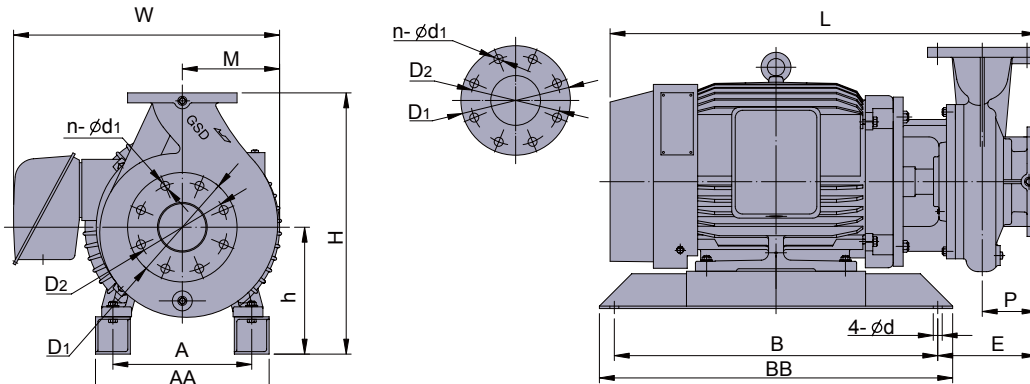

FIG.1

(2P)

型号 Type	FIG.	A	AA	B	BB	d	E	H	h	L	M	P	W	D <sub>1</sub>	D <sub>2</sub>	n-φd <sub>1</sub>
G-30-25	1	112	159	250	290	14	92	221	101	341.5	86	60	216	115	85	4-Φ14
G-31-40	1	125	177	290	342	14	86.5	240	110	371	95.5	65	242	150	110	4-Φ18
G-32-40	1	140	192	290	342	14	104.5	250	120	408	103.5	65	268	150	110	4-Φ18
G-31-50	1	125	177	290	342	14	86.5	240	110	371	95.5	65	242	150	125	4-Φ18
G-32-50	1	140	192	290	342	14	125.5	260	120	429	104	80	268	165	125	4-Φ18
G-33-50	1	140	210	290	340	14	142.5	345	165	446	132	92	296	165	125	4-Φ18
G-35-50	1	190	252	390	436	18	125	325	145	502.5	132	92	312	165	125	4-Φ18
G-37-50	1	216	278	390	436	18	138	345	165	544	143	92	355	165	125	4-Φ18
G-310-50	1	216	266	390	450	14	168	412	187	574	161	100	372	185	125	4-Φ18
G-32-65	1	140	192	290	342	14	125.5	280	120	429	110	80	275	185	145	4-Φ18
G-33-65	1	140	192	290	342	14	125.5	325	145	429	110	80	275	185	145	4-Φ18
G-35-65	1	190	252	390	436	18	125	367	187	503	132	92	312	185	145	4-Φ18
G-37-65	1	216	278	390	436	18	138	345	165	544	143	92	356	185	145	4-Φ18
G-310-65	1	216	278	390	436	18	153	345	165	559	142	92	353	185	145	4-Φ18
G-315-65	1	254	324	500	560	18	166	460	235	696	161	100	436	185	145	4-Φ18
G-320-65	1	254	324	500	560	18	166	460	235	696	161	100	436	185	145	4-Φ18
G-33-80	1	140	192	290	342	14	151.5	280	120	455	127	100	291	200	160	8-Φ18
G-35-80	1	190	252	390	436	18	134	305	145	511.5	128	100	308	200	160	8-Φ18
G-37-80	1	216	278	390	436	18	153	385	165	559	148	100	361	200	160	8-Φ18
G-310-80	1	216	278	390	436	18	168	385	165	574	148	100	359	200	160	8-Φ18
G-315-80	1	254	324	500	560	18	166	455	235	696	173	100	448	200	160	8-Φ18
G-320-80	1	254	324	500	560	18	166	495	235	696	173	100	448	200	160	8-Φ18
G-325-80	1	254	324	500	560	18	247	495	235	800	173	100	448	200	160	8-Φ18
G-330-80	1	279	349	580	640	18	201.5	525	255	816.5	199	100	539	200	160	8-Φ18
G-340-80	1	279	349	650	710	18	202.5	545	255	861	204	110	544	220	160	8-M16
G-350-80	1	318	388	650	710	18	226.5	575	275	926	214	110	579.5	220	160	8-Φ18
G-35-100	1	190	260	290	340	14	193	367	187	520.5	148	100	328	220	180	8-Φ18
G-37-100	1	216	278	390	436	18	156	345	165	562	148	100	361	220	180	8-Φ18
G-310-100	1	216	278	390	436	18	171	345	165	577	148	100	359	220	180	8-Φ18
G-315-100	1	254	324	500	560	18	169	460	235	699	161	100	436	220	180	8-Φ18
G-320-100	1	254	324	500	560	18	169	460	235	699	161	100	436	220	180	8-Φ18
G-325-100	1	254	324	500	560	18	269	505	235	822	192	110	467	220	180	8-Φ18
G-330-100	1	279	349	580	640	18	217.5	525	255	832.5	199	110	539	220	180	8-Φ18
G-340-100	1	279	349	650	710	18	199.5	525	255	858	196	110	536	220	180	8-Φ18
G-350-100	1	318	388	650	710	18	226.5	565	275	926	204	110	568	220	180	8-Φ18
G-360-100	1	318	388	650	710	18	226.5	575	275	926	214	110	578	220	180	8-Φ18
G-375-100	1	356	456	750	810	24	175	632	332	935	245	110	640	220	180	8-Φ18
G-340-150	1	279	349	650	710	18	227.5	535	255	886	206	140	546	285	240	8-Φ22
G-350-150	1	318	388	650	710	18	251.5	555	275	951	206	140	571	285	240	8-Φ22
G-360-150	1	318	388	650	710	18	251.5	555	275	951	206	140	571	285	240	8-Φ22
G-375-150	1	356	456	750	810	24	206	632	332	966	245	140	640	285	240	8-Φ22
G-3100-150	1	406	506	750	810	24	237.5	657	357	1059.5	255	140	785	285	240	8-Φ22



## 外形及安装尺寸 Installation dimensions

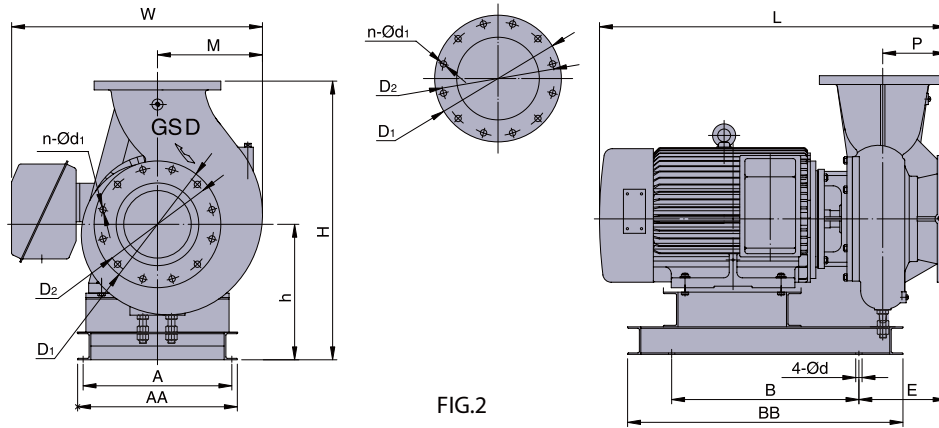

FIG.2

(4P)

型号 Type	FIG.	A	AA	B	BB	d	E	H	h	L	M	P	W	D <sub>1</sub>	D <sub>2</sub>	n-φd <sub>1</sub>
G-32-50	1	140	203	290	340	14	154.5	422	197	458	161	100	331	185	125	4-Φ18
G-33-50	1	160	230	290	340	14	183	400	175	503	161	100	325	185	125	4-Φ18
G-32-65	1	140	210	290	340	14	139.5	345	165	443	132	92	302	185	145	4-Φ18
G-33-65	1	160	230	290	340	14	183	400	175	503	161	100	325	185	145	4-Φ18
G-35-65(I)	1	190	253	290	340	14	194	489	219	517	192	100	378	200	145	4-Φ18
G-35-65	1	190	253	290	340	14	194	509	219	517	201	100	393	200	145	4-Φ18
G-37-65	1	216	286	390	440	14	174	498	208	580	201	100	418	200	145	4-Φ18
G-33-80	1	160	230	290	340	14	183	435	175	503	173	100	337	200	160	8-Φ18
G-35-80	1	190	260	390	440	14	140	447	187	513	173	100	359	200	160	8-Φ18
G-37-80	1	216	286	390	440	14	180	477	207	580	192	100	409	200	160	8-Φ18
G-310-80	1	216	286	390	450	14	193	497	207	618	201	100	418	200	160	8-Φ18
G-315-80	1	254	324	500	560	18	172	525	235	702	201	100	476	200	160	8-Φ18
G-35-100	1	190	260	390	440	14	162	457	187	535	192	110	378	220	180	8-Φ18
G-37-100	1	216	286	390	440	14	190	477	207	596	192	110	409	220	180	8-Φ18
G-310-100	1	216	286	390	440	14	209	477	207	634	192	110	409	220	180	8-Φ18
G-315-100	1	254	324	500	560	18	191	535	235	721	214	110	490	220	180	8-Φ18
G-320-100	1	254	324	500	560	18	213	535	235	765	214	110	490	220	180	8-Φ18
G-325-100	1	279	359	580	640	18	220.5	672	312	835	255	110	596	220	180	8-Φ18
G-330-100	1	279	359	580	640	18	220.5	672	312	835	255	110	596	220	180	8-Φ18
G-35-150	1	190	253	390	450	14	190	499	219	563	206	140	392	285	240	8-Φ22
G-37-150	1	216	286	390	450	14	218	487	207	624	206	140	423	285	240	8-Φ22
G-310-150	1	216	286	390	450	14	237	487	207	662	206	140	423	285	240	8-Φ22
G-315-150	1	254	324	500	560	18	222	535	235	752	227	140	502	285	240	8-Φ22
G-320-150	1	254	324	500	560	18	244	535	235	796	227	140	503	285	240	8-Φ22
G-325-150	1	279	349	580	640	18	243	605	255	858	249	125	589	285	240	8-Φ22
G-330-150(I)	1	279	359	580	640	18	259	667	287	874	268	140	608	285	240	8-Φ22
G-330-150	1	279	349	580	640	18	243	605	255	858	249	125	590	285	240	8-Φ22
G-340-150	1	279	359	650	710	18	241	667	287	899	268	140	608	285	240	8-Φ22
G-315-200	1	254	324	500	560	18	254	535	235	784	241	160	516	340	295	8-Φ22
G-320-200	1	254	324	500	560	18	276	535	235	828	241	160	516	340	295	8-Φ22
G-325-200	1	279	359	580	640	18	284	607	287	898.5	255	160	595	340	295	8-Φ22
G-330-200	1	279	359	580	640	18	284	647	287	898.5	268	160	608	340	295	8-Φ22
G-340-200(I)	1	279	359	650	710	18	266	678	287	924	286	160	626	340	295	8-Φ22
G-340-200	1	279	359	650	710	18	266	647	287	924	268	160	608	340	295	8-Φ22
G-350-200(I)	1	318	398	650	710	18	290	697	307	989	287	160	652	340	295	8-Φ22
G-350-200	1	318	398	650	710	18	290	697	307	989	287	160	652	340	295	8-Φ22
G-3100-200	1	460	500	600	790	24	204.5	926	486	1153.5	321	200	852	340	295	8-Φ22
G-320-250	1	254	334	580	640	18	291	647	267	883	303	205	580	395	350	12-Φ22
G-325-250	1	279	359	580	640	18	338.5	667	287	953.5	304	205	644	395	350	12-Φ22
G-330-250	1	279	359	580	640	18	338.5	667	287	953.5	304	205	644	395	350	12-Φ22
G-340-250	1	279	359	650	710	18	326	762	312	984	331	200	671	395	350	12-Φ22
G-350-250	1	318	398	650	710	18	350	757	307	1049	331	200	696	395	350	12-Φ22
G-360-250(I)	1	318	398	650	710	18	350	757	307	1049	318	200	683	395	350	12-Φ22
G-360-250	1	318	398	650	710	18	350	757	307	1049	318	200	683	395	350	12-Φ22
G-375-250(I)	1	356	456	750	810	24	298	782	332	1058	319	200	714	395	350	12-Φ22
G-375-250	1	356	456	750	810	24	298	782	332	1058	319	200	714	395	350	12-Φ22
G-3100-250	2	460	500	600	790	24	204.5	986	486	1154	360	200	890	395	350	12-Φ22
G-360-300	1	410	450	550	750	18	257	970	450	1099	378	230	743	445	400	12-Φ23



## 外形及安装尺寸 Installation dimensions

(4P)

型号 Type	FIG.	A	AA	B	BB	d	E	H	h	L	M	P	W	D <sub>1</sub>	D <sub>2</sub>	n-φd <sub>1</sub>
G-375-300	2	410	450	550	735	19	258	975	455	1108	381	230	776	445	400	12-Φ22
G-3100-300	2	460	500	600	810	24	252.5	1006	486	1202	381	230	911	445	400	12-Φ22
G-3125-300(I)	2	540	580	680	875	24	285.5	1096	516	1241	383	230	913	445	400	12-Φ22
G-3125-300	2	540	580	680	890	24	303.5	1012	492	1259	381	230	911	445	400	12-Φ22

注: 以上为铸铁材质外形尺寸, 不锈钢结构请咨询本公司销售人员。

Note: The above size is of cast iron material pump, if you want the size of steel material pump, please contact our salesman.

## 安装示意图 Installation sketch map

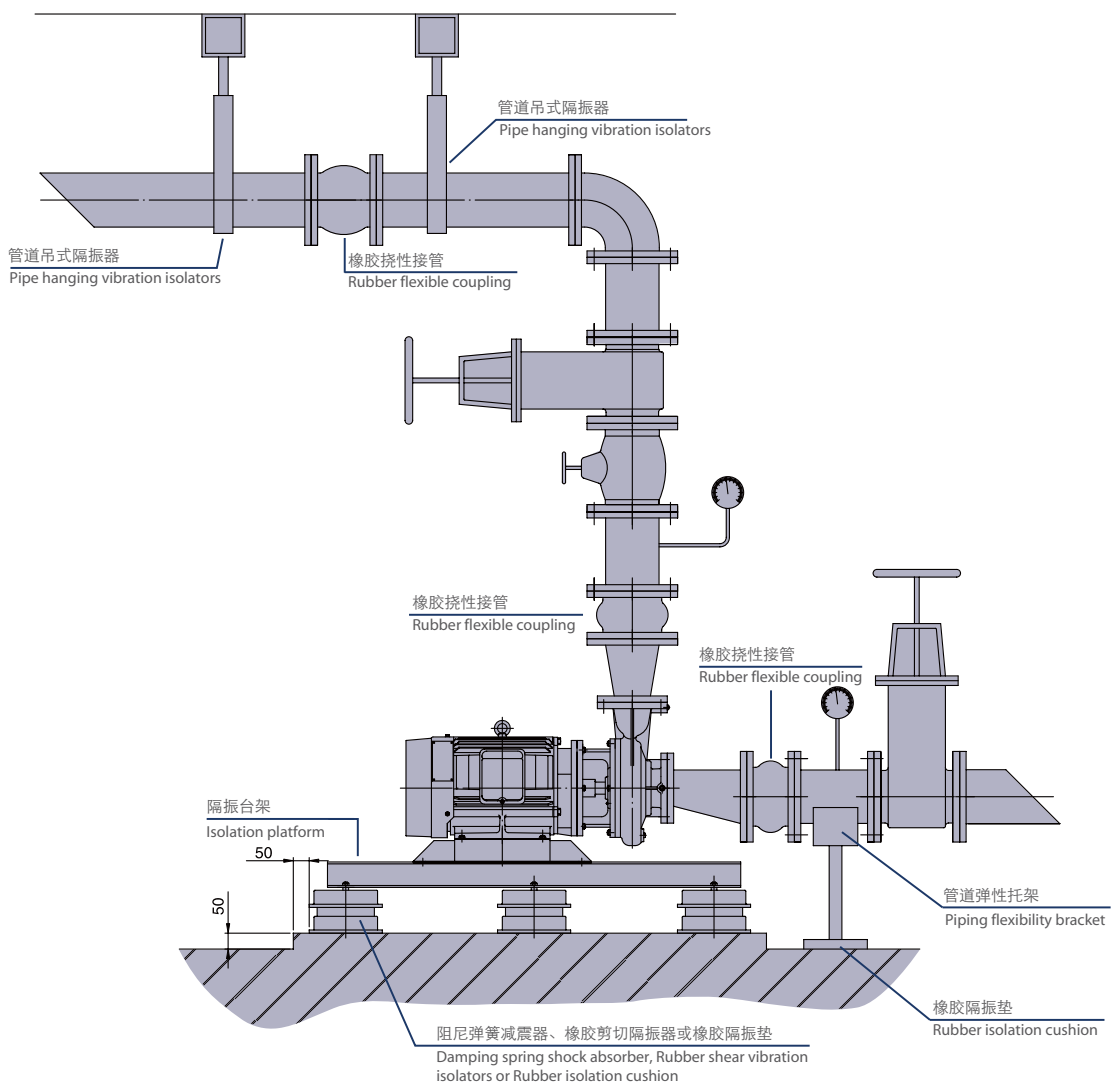

本型录内容如有变更, 恕不另行通知。  
We reserve the right to change content without notice.